

Basic WiFi set up instructions for the [Control DeviceMaster Air1](#) Serial to WiFi adapter.

The following is a basic step instructions only **Tmanufacturing does not offer any technical support for WiFi set up**. For complete instructions please refer to [Control](#).

STEP 1

INITIAL WLAN CONFIGURATION OF WIRELESS ADAPTER

1. *Assign a static IP address to the computer that you are using to configure the wireless adapter that is in the address *range of the default IP address 192.168.0.30.

*NOTE: The computer that you are using for initial configuration must have an IP address within the same range *as the WLAN IP address of the wireless adapter.

2.* Attach the antenna.

3.* Connect the wireless adapter labeled WLAN to the same Ethernet segment as the host PC using a standard **network cable.

4.* Apply power.

5. *Open web browser and enter 192.168.0.30. (default IP address)

6. *Type *admin* in the *User Name* field and select *OK*.

7. *Select the *Run Wizard* button when the *Home* screen appears.

8. *Select *Next* when the Welcome screen appears.

9.* Optionally, enter a password in the *Set Password* screen, and select *Next*.

10. *Select *Infrastructure mode*.

NOTE: See Ad Hoc Mode CD instructions if you want to configure the wireless adapter to operate in Ad Hoc mode. Infrastructure mode requires an access point or wireless router for operation.

*a. *Enter the SSID for the access point.

*b. *Select *Site Survey* to select a wireless network.

*c. *Select the appropriate network and *Connect*. Your site may have multiple networks available.

11. *Select *Close*.

12. *Select *Next* in the *Set Wireless LAN Connection* screen to continue.

13. *Optionally, select *Enabled*, the appropriate values for the encryption method, WEP Mode, keys, and select ***Next*. Encryption is disabled by default, but it is recommended that you enable encryption on all wireless **devices to eliminate security problems with the network.

14. *Select *Restart* when the *Setup Completed* screen appears.

15. *Select *Close*.

16. *If necessary, start your web browser, and enter the wireless adapter WLAN IP address. The default WLAN IP **address is 192.168.0.30.

17. *Enter *Admin* as the *User Name*, enter the password, and select *OK*.

18.* Select the *Network* tab.

19. *Select the Static IP Address and enter appropriate values for your network and select *Apply*.

20. *Select *Continue*.

21. *Close the web browser.

22. *If necessary, reset your computer*s IP address back to its original values.

23. *Ping the new IP address and verify that it responds.

24. *Remove the Ethernet cable from the network port and use the appropriate procedure for your

environment.

Use the following procedure to use the wireless adapter as a wireless Rain8net server.

1. *Reconnect the 4* Ethernet jumper cable between the WLAN and LAN port of the wireless adapter.
2. *Verify that the LEDs on the top of the unit are lit.
*NOTE: The *Status* LED flashes while booting and it takes approximately 15 seconds for the boot loader to **complete the cycle.
3. *Ping the IP address that you pinged in the steps above.

STEP 2

Initial NS-Link Driver Installation for the Serial Portion

Windows XP and Windows Server 2003: NS-Link Installation

Use this procedure to install and configure the NS-Link device driver for your device.

It is highly recommended that you get the latest driver from ftp://ftp.control.com/dev_mstr/air/drivers/.

1. *If necessary, unzip the self-extracting files from the Control media or ftp/web site. From the *Start* button, **select **Control Panel*. Windows Server 2003: Select the *Add Hardware* item. Windows XP: Double-click **on the **Add Hardware* icon.
2. * Select *Next*.
3. *Select *Yes, I have already connected the hardware* and *Next*.
4. *Highlight *Add a new hardware device* (at the end of the list) and select *Next*.
5. * Select "Install the hardware that I manually select from a list (Advanced)* and *Next*.
6. *Highlight *Multi-port serial adapters* and select *Next*.
7. * Select the *Have Disk* button.
8. *Use *Browse* button to locate the unzipped installation files and select *Open*.
9. *Select *OK*.
10. *From the *Models* list, highlight the device you are installing and *Next*. It is not necessary to select a file, just *browse to the directory and select *Open*.
11. *Select the *Next* button to start the driver installation.
12. *Select *Continue Anyway* to proceed. NOTE: It may take up to several moments for the operating system to **lead the driver on the first port.
13. *Select the *Finish* button to complete the installation process for the device.
14. *Select *Install the software automatically (Recommended)* and *Next*.
15. *Select *Continue anyway* to proceed.
16. *Select the *Finish* button to complete the driver installation process for this port.
17. *Close the Control Panel.
18. *Right-click *My Computer*, select *Manage*, and highlight *Device Manager*.
19. *Expand the *Multi-port serial adapters* entry, right-click on the device you are installing, and select the ***Properties* menu item.
20. *Select the *Network Connections* tab.
21. *Select *MAC Mode* or *IP Mode* and follow the appropriate procedure below. To configure an IP address or **DHCP usage for the device, you must associate a MAC address to the device before you can change the IP **address. If you do not *associate the MAC address to the device, you will not be able to change the IP address, **disable the DHCP discovery *messages, retrieve device network information, reset the device, or use the ***Advisor* tab.
22. *To use MAC MODE you must connect the device to the local network segment or an NIC on the host system. If *you do not associate the MAC address to the device, you will not be able to change the IP address, disable DHCP *discovery messages, retrieve device network information, reset the device, or use the Advisor tab.
*a.*Enter the address from the MAC address label on the device or select the MAC address from the droplist. *If you enter the MC address, make sure that you use the correct format: 00 C0 4E xx xx xx. A space must **separate each pair of digits. NOTE: The MAC address does not appear in the droplist if the

device is on another network segment. In this case, you must manually enter the MAC address.

- *b.*Select "OK" to program the driver with the MAC address of the device. You must close the Device Properties page before you can program a different IP address into the device. To program the device for use with an IP address, see Programming the IP Address on page 52. To configure NS-Link in MAC mode to run efficiently, see Disabling DHCP Requests (MAC Mode) on page 55.
- *To use IP Mode - You can select IP Mode if the address in the device has been programmed with a suitable IP address for your network. If you do not associate the MAC address with the device, you will not be able to change the IP address, disable DHCP discovery messages, retrieve device network information, reset the device, or use the Advisor tab.
- *a.*Select IP Mode.
- *b.*Enter the IP address of the device.

23. *If you are done configuring the device, close the Device Manager.

24. *Configure port as 4800 bps N-8-1.

STEP 3

The wireless adapter platform includes the following utilities for Microsoft system. PortVision is the fastest and easiest way to configure network information if you have access to a Windows 2000, Windows XP, or Windows Server 2003 system. PortVision requires that you connect the wireless adapter to the same network segments as the Microsoft system during the configuration process. See Installing, Updating, and Removing PortVision. It is recommended that you download the latest version of PortVision if you are connected to the internet. The latest version can be located at ftp://ftp.comtrol.com/dev_mstr/portvision/

Factory Default Settings for the WLAN Port

DeviceMaster AIR WLAN port defaults. You can reset the DeviceMaster AIR to the factory defaults by selecting the Reset button.

WLAN Port Default Setting*****IP address mode Static
Operating Mode Infrastructure****IP address 192.168.0.30
SSID default*****Subnet mask 255.255.255.0
Channel 6*****Username admin (all lower case)
Encryption No
Administrator
password Blank (no password needed)

STEP 4

WiFi Rain8net Module Installation

A 12-position terminal strip is found on all modules. Connect the 24 VAC to ONLY ONE module; the remaining modules are powered by means of the 8-conductor network cable. There is a single RS232 connection between the controlling computer and the master Rain8. The 24VAC power and network communications are transferred from master to slave-to-slave etc. The network connection for the slave units are an 8-conductor RJ45. Each slave has a pair of these modular jacks to pass on data and power to the next one in a daisy chain. Each slave also has a RS232 connection that is used only to assign the address during the initial configuration.

INSTALLATION CONTROLLER LOCATION

Select a mounting location that is close to an electrical outlet and the valve wires that will connect to it. The controller should not be exposed to water. If used outside, it is necessary to provide a weather-proof housing for your Rain8. <http://www.wgldesigns.com/r8outdoor.html>. Mount your controller to a smooth dry surface by means of the enclosed Velcro strips.

WIRING THE VALVES

If the maximum distance is less than 600 feet, use a single 20-gauge, plastic insulated wire for each valve. Each valve has two wires. One wire is designated as the common. All of the common wires can be

connected together to one wire going to the controller. All connections should be made using wire nuts in grease caps to prevent corrosion. Only one valve should be connected to each zone. The rated output is 24VAC at .25 amps (250ma), per zone. Some valves require a greater current than .25 amps to initially open and drop back to a lower valve. This will present no problem as long as the drop-back valve is .25 amps or less.

CONNECTING THE VALVE WIRES TO THE CONTROLLER

Determine which valve is to be connected to each zone. Insert each valve wire into its respective position on the terminal strip and gently tighten the setscrew. Connect the common wire from the valves to the terminal labeled *common*.

CONNECTING THE TRANSFORMER (Master unit only)

Connect the 24VAC transformer to the two terminals labeled *24VAC*. Note that this is required only on the first module installed, as the power for additional units is supplied by means of the network connections.

WIRING THE RS232 CONNECTION (Master unit only)

Connect the RS232 cable's RJ11 plug to the RJ11 jack labeled *RS-232* on the left side of the module. The other end of the cable with the DB9 connector attaches to your computer's serial port.

ADDING ADDITIONAL MODULES

As many as 254 additional 8-zone modules may be added by daisy-chaining the modules' *Rain8 Network Jacks*.

Individual Rain8net modules are shipped set to an address of *1* and the default run timers disabled. For most 8-zone, single-module applications this is the desired configuration and the hardware installation is complete.

***PREPARE TO CONFIGURE THE RAIN8 MODULE** (only if you are installing multiple modules or setting max run time feature)

Please note that the Rain8 terminal strip is removable. Gently unplug the portion with screw heads from the socket mounted on the PCB. Remove the Rain8 from the wall and bring it to the location of the PC that will be used for programming.

Connect the DB9 cable and adapter into the RJ11 jack on the Rain8 labeled *RS-232*. The DB9 end is plugged into a serial port on your PC. It is not necessary to provide power for the unit as it can derive what it needs for programming from the serial port. It is very important that no attempt is made to program modules that are still connected to the network. Right-click on Rain8 Irrigation Server Icon and select *Configure Rain8net Module Address*. Click on OK. You should now see the Rain8 Configuration screen. Set up the Serial Port assignment by selecting the COM port number. At this point there is no need for anything to be connected to the Rain8 other than the serial cable. The power for the unit is derived from the serial port.

Rain8 Configuration Software. Download software from:
http://www.wgldesigns.com/downloads/rain8net_software.zip

CONFIGURING YOUR RAIN8NET

Select desired address (1-255) for this module from list box. If the default run time feature is not desired, click *disable* and click on *load Module*. If the timers are to be enabled do not check *disable*. enter the

desired default run time for each zone in the appropriate box. Click on *load Module*. Click on *Configure Now*. Click on *done*.

*Because any RF signal can be disrupted, it is highly recommended Default run timers be set for all zones to prevent over watering.

Dimensions

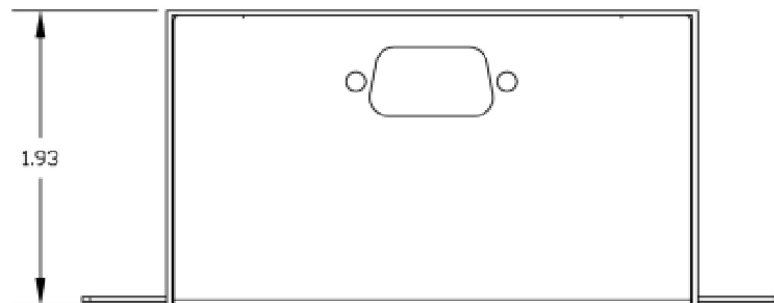
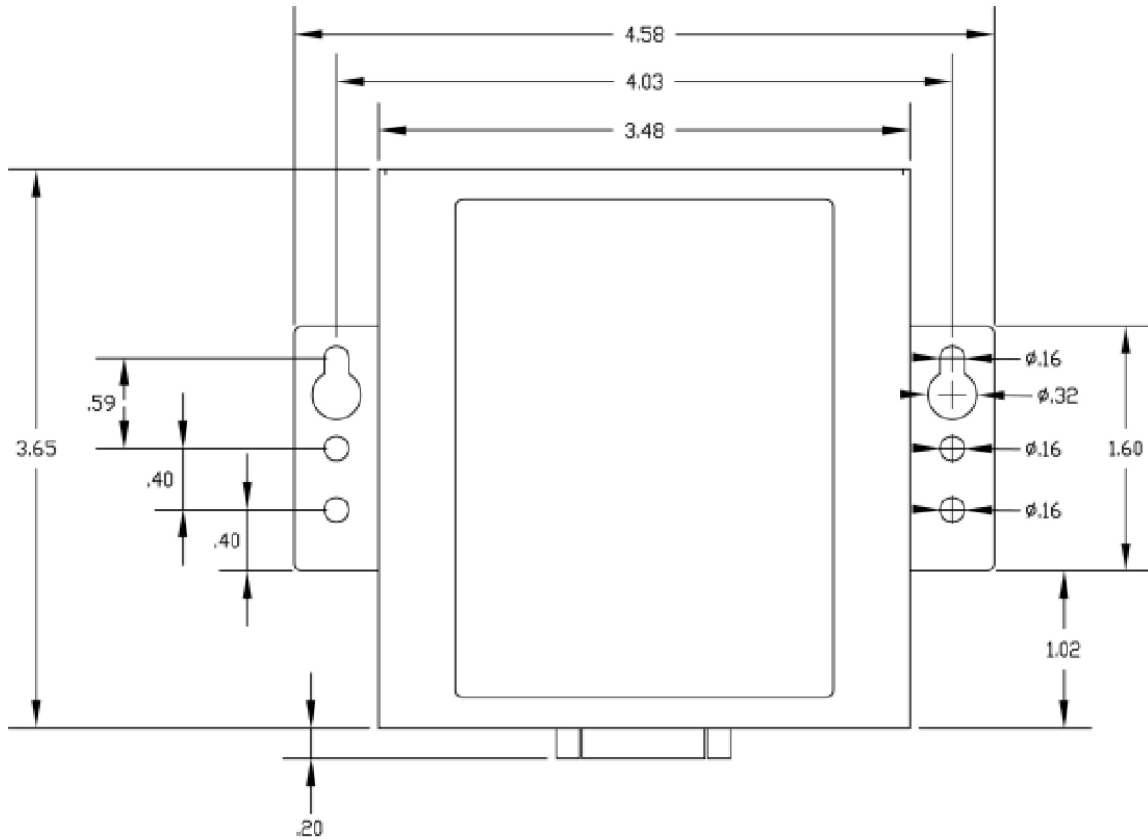

Problems or Questions?

TROUBLESHOOTING RESOURCES

If for some reason you have difficulty configuring your DeviceMaster Air, it is highly recommended you contact technical support at Control first.

Control Support at www.control.com (763-494-4100)

Instructions on CD

